

OPENSSD Project

Jasmine BOARD

OPENSSD Project		
Title Jasmine Board / TITLE		
Size A4	Document Number INDTC11-110328-B-SCH	Rev 1
Date: Friday, April 29, 2011	Sheet 1	of 13

Controller SATA Section / SATA Connector

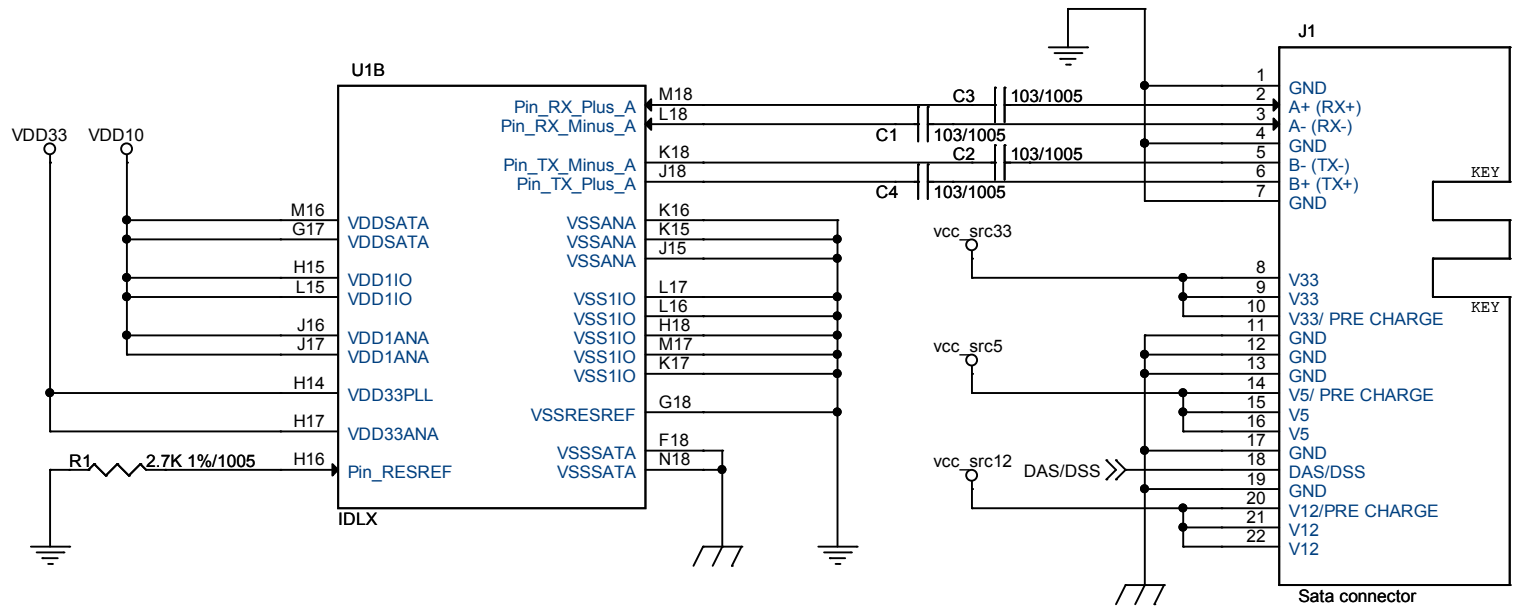

Activity LED control

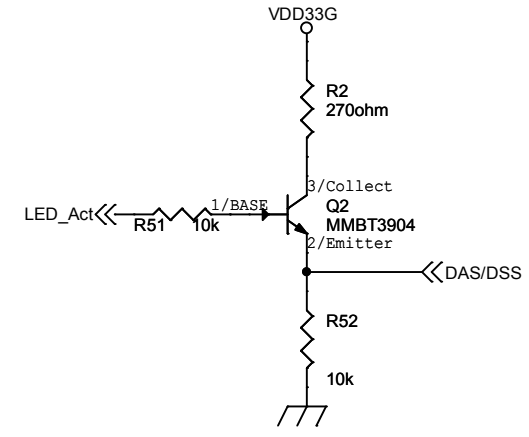

Power switch

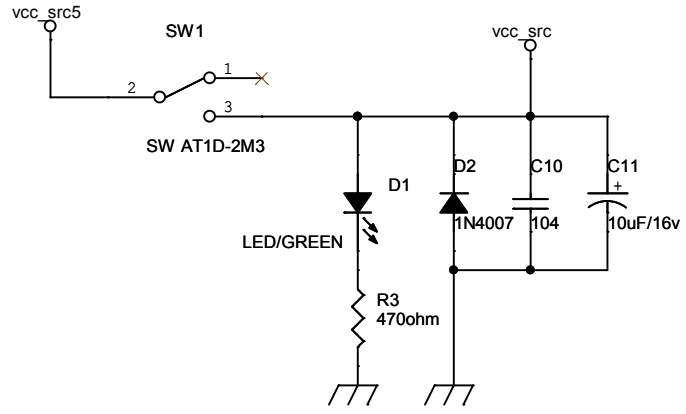

Super Cap

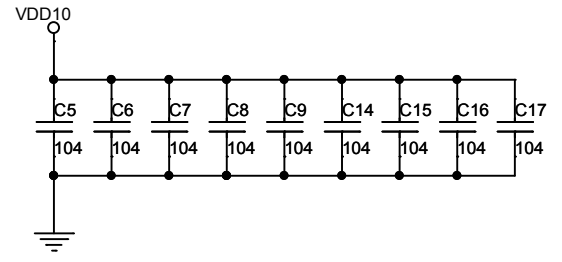
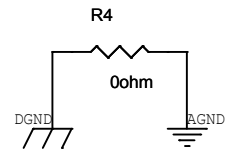
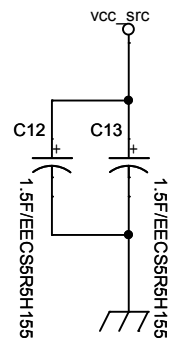

OPENSSD Project		
Title Jasmine Board / SATA PART		
Size A4	Document Number INDTC11-110328-B-SCH	Rev 1
Date Friday, April 29, 2011	Sheet 2	of 13

Controller SDRAM Interface Section

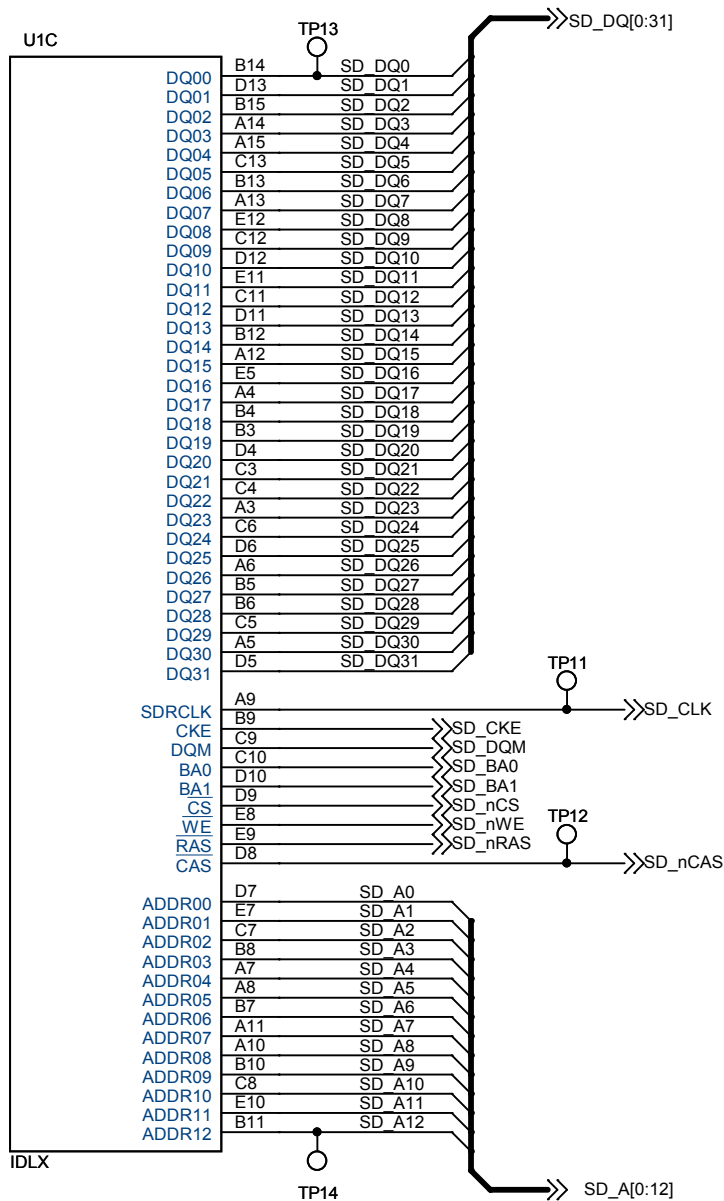

SDR SDRAM / x32 / Mobile type

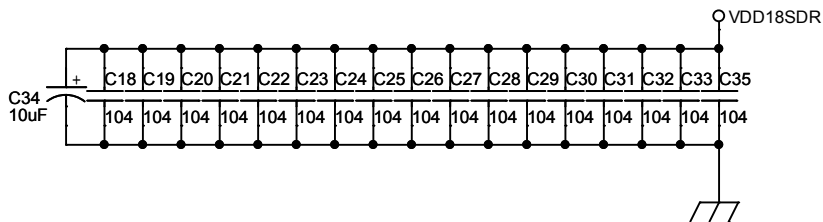
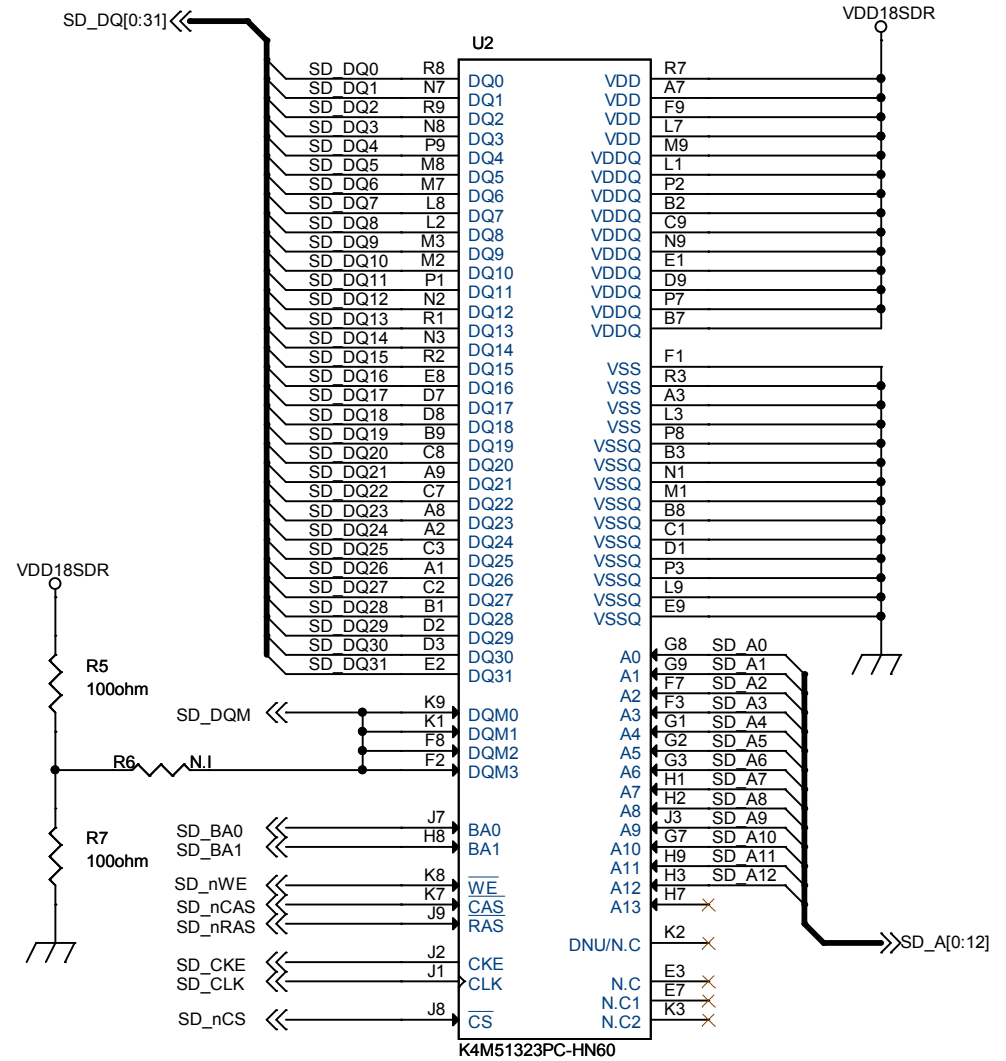

OPENSSD Project		
Title Jasmine Board / SDRAM PART		
Size A4	Document Number INDTC08-081022-B-SCH	Rev 1
Date: Friday, April 29, 2011	Sheet 3	of 13

Controller Nand Module Interface Section

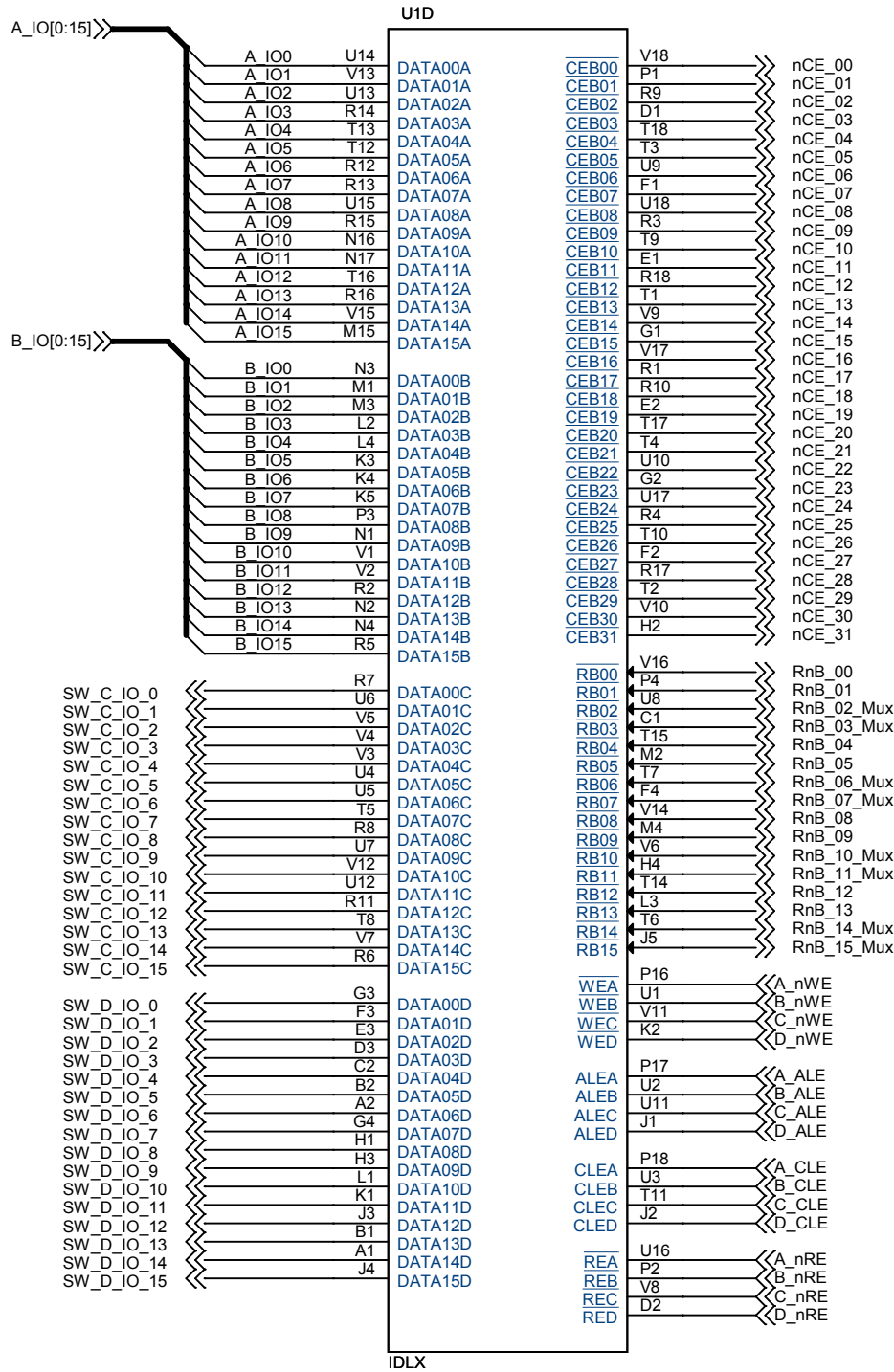

OPENSDD Project		
Title Jasmine Board / Nand PART		
Size A4	Document Number INDTC08-081022-B-SCH	Rev 1
Date Friday, April 29, 2011	Sheet 4	of 13

Nand Module Connector Interface
Channel : A/B_0 way

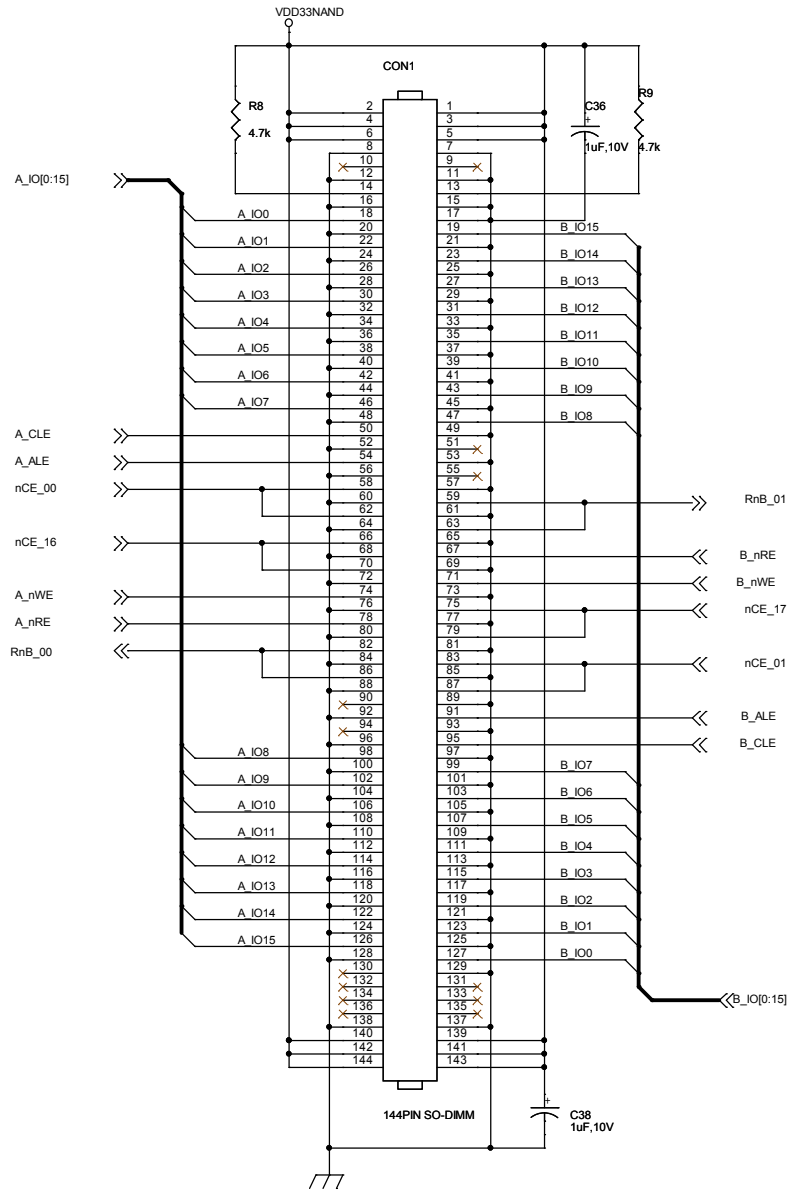

Nand Module Connector Interface
Channel : A/B_1 way

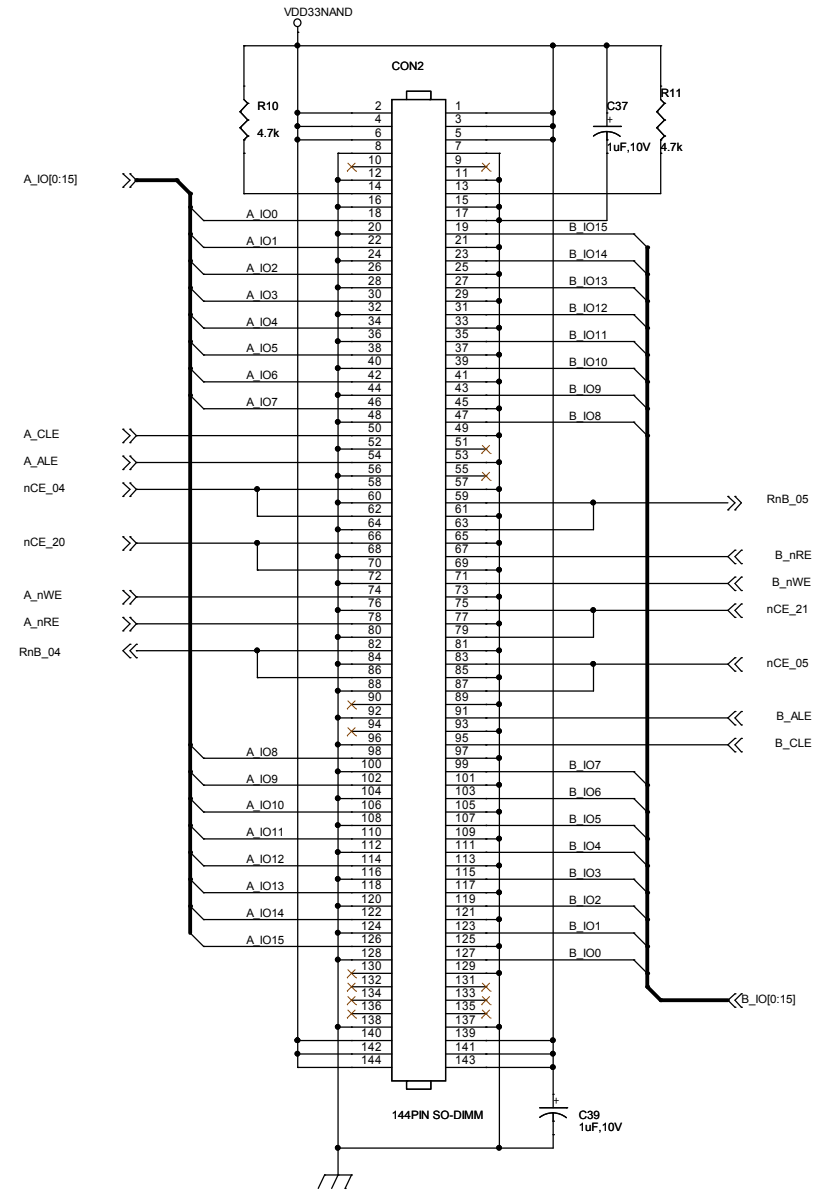

Nand Module Connector Interface
Channel : A/B _ 2 way

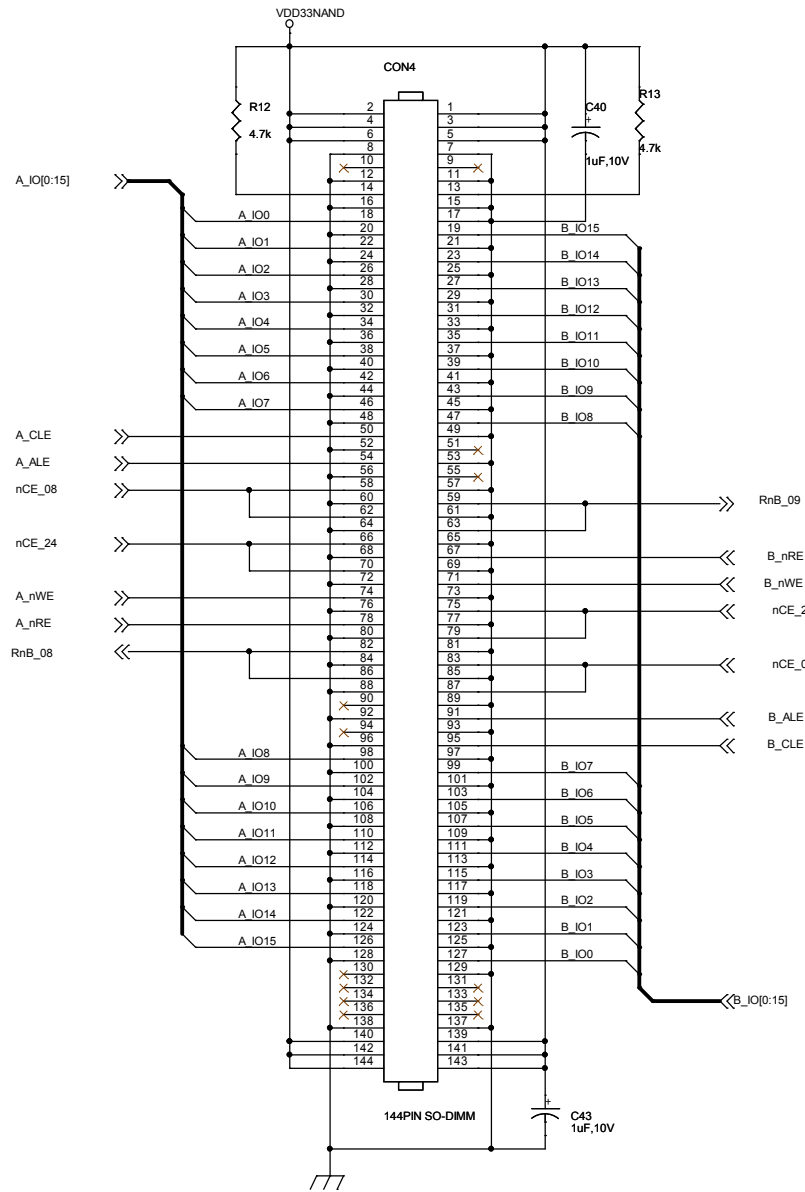

Nand Module Connector Interface
Channel : A/B _ 3 way

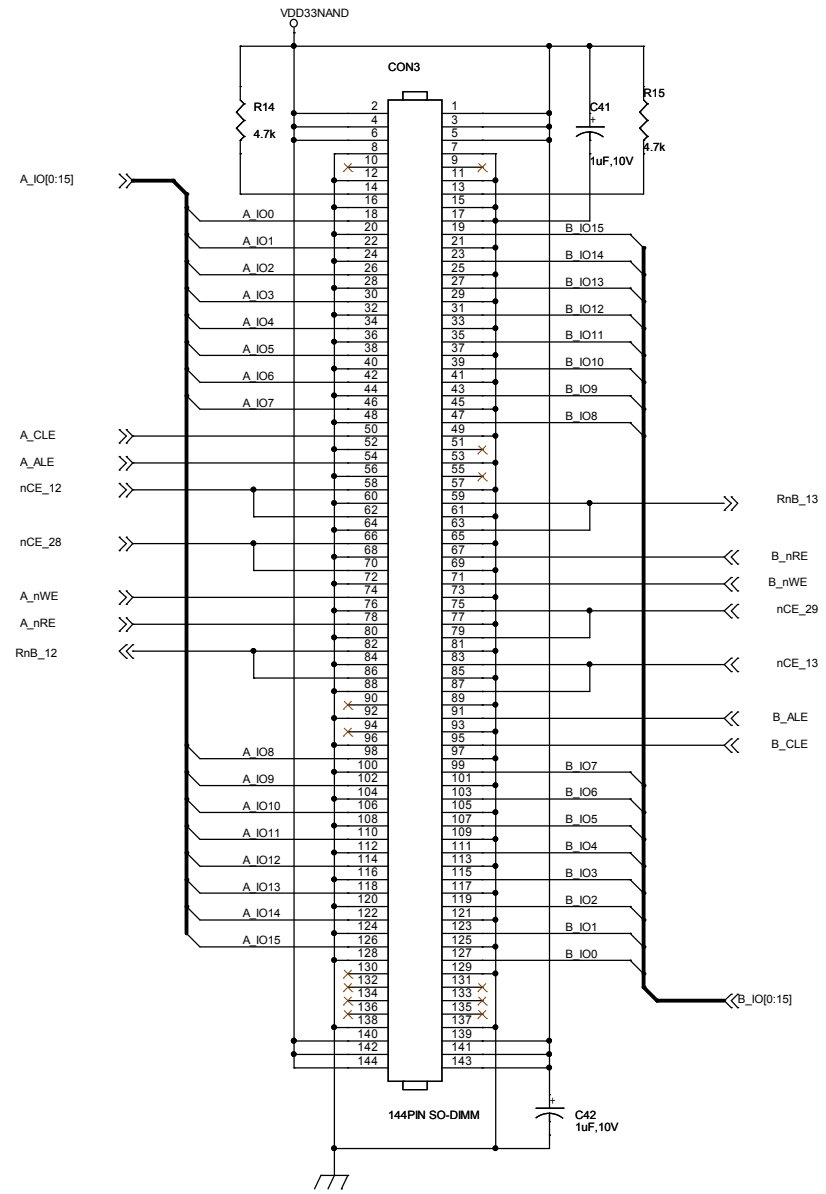

OPENSDD Project			
Title Jasmine Board / Nand socket PART			
Size A3	Document Number INDTC08-081022-B-SCH	Rev 1	
Date: Friday, April 29, 2011	Sheet 6	of 13	

Nand Module Connector Interface
Channel : C/D_0 way

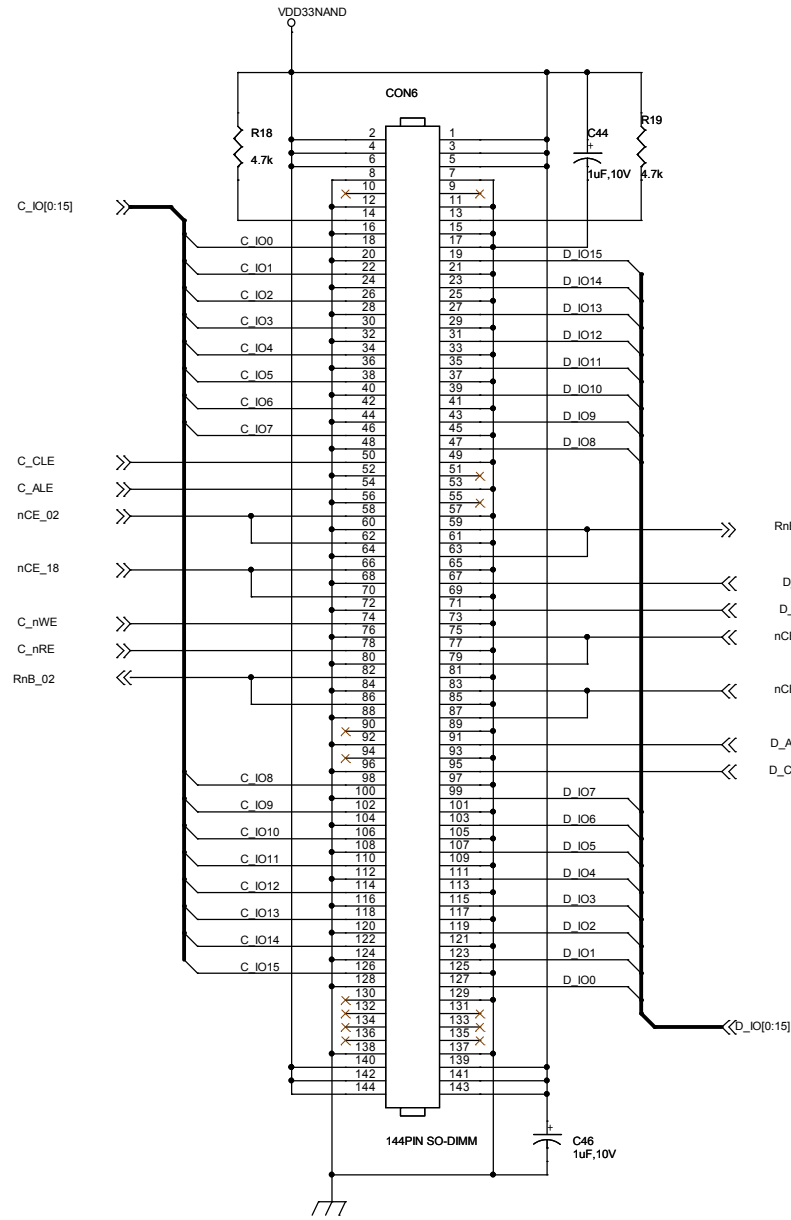

Nand Module Connector Interface
Channel : C/D_1 way

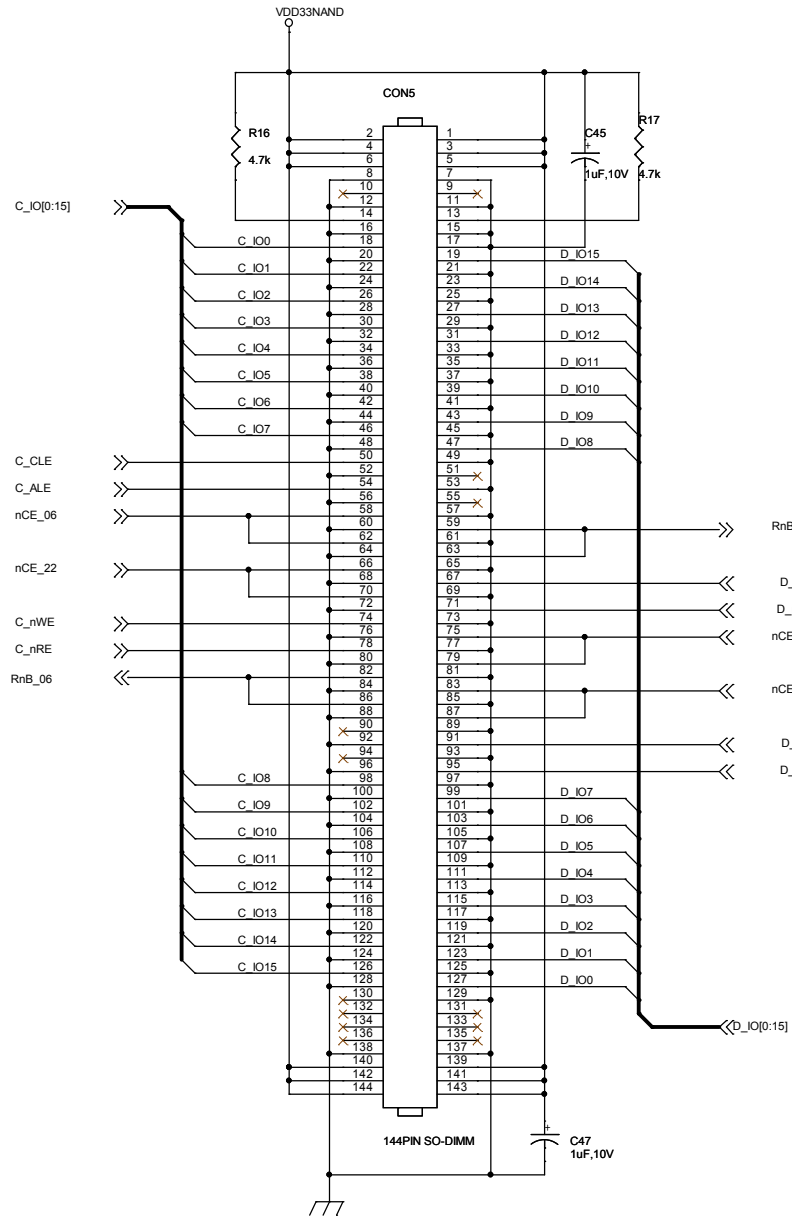

OPENSSED Project			
Title	Jasmine Board / Nand socket PART		
Size	Document Number	Rev	
A3	INDTC08-081022-B-SCH	1	
Date:	Friday, April 29, 2011	Sheet	7 of 13

Nand Module Connector Interface
Channel : C/D _2 way

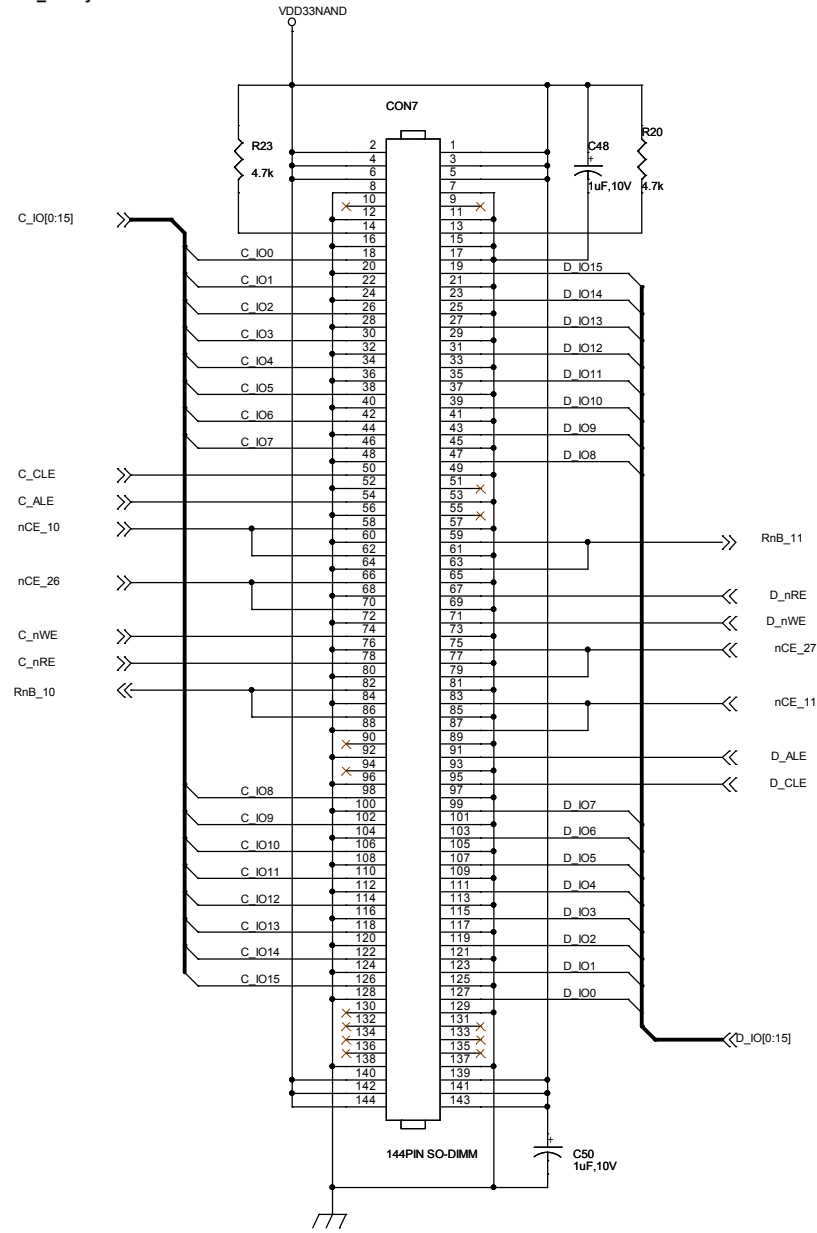

Nand Module Connector Interface
Channel : C/D _3 way

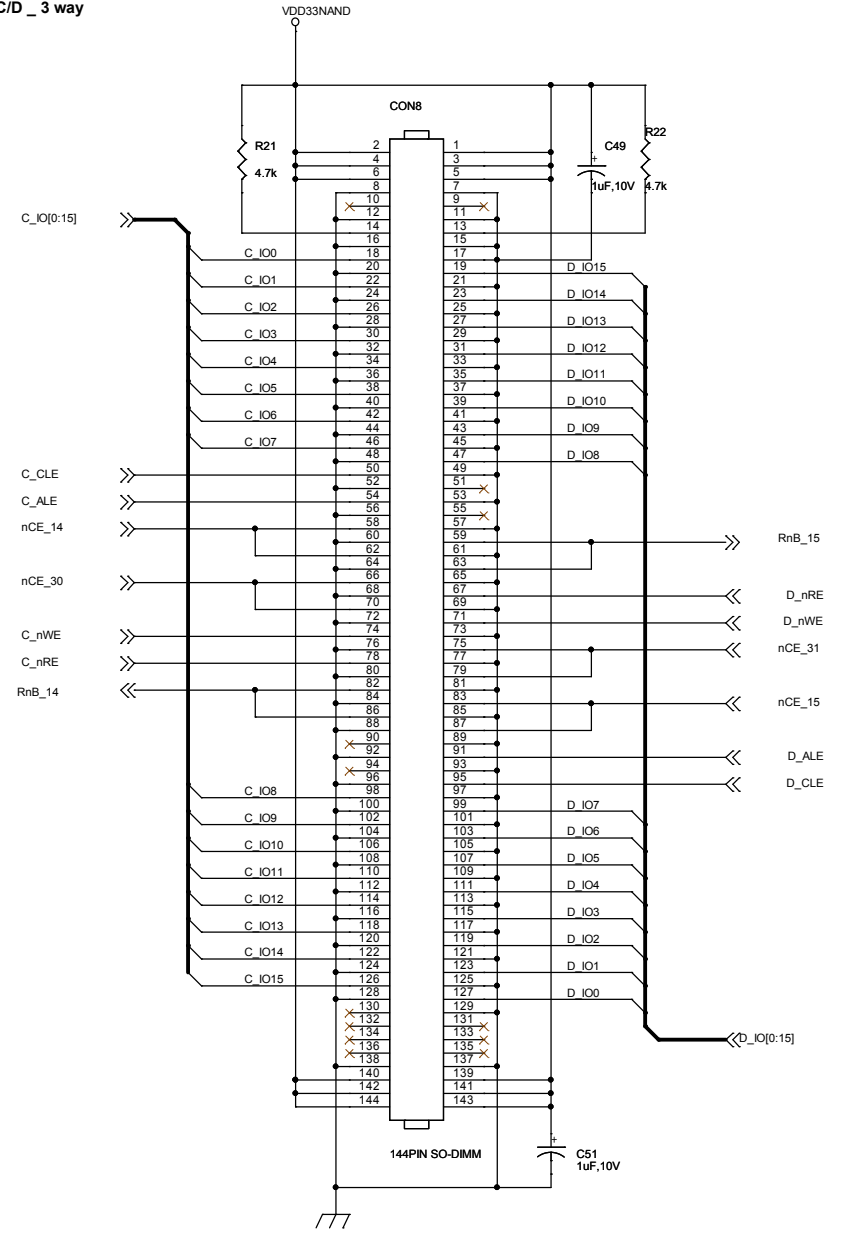

OPENSSED Project		
Title	Jasmine Board / Nand socket PART	
Size	Document Number	Rev
A3	INDTC08-081022-B-SCH	1
Date:	Friday, April 29, 2011	Sheet 8 of 13

Electric SPDP Switch

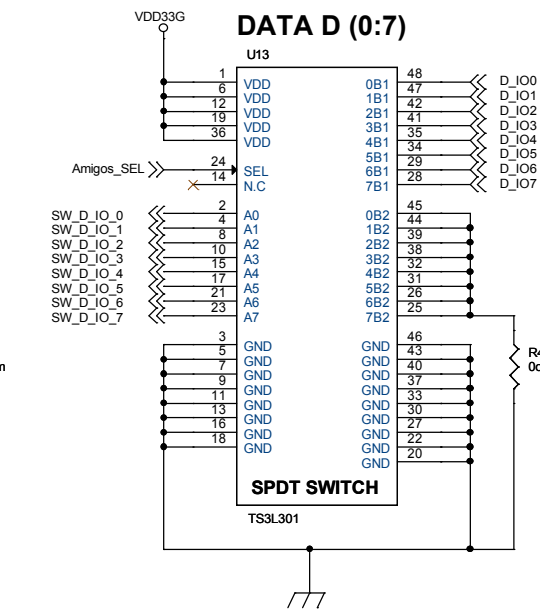
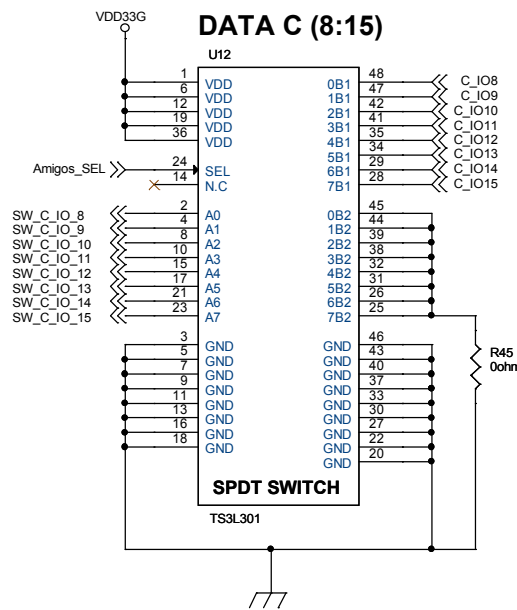
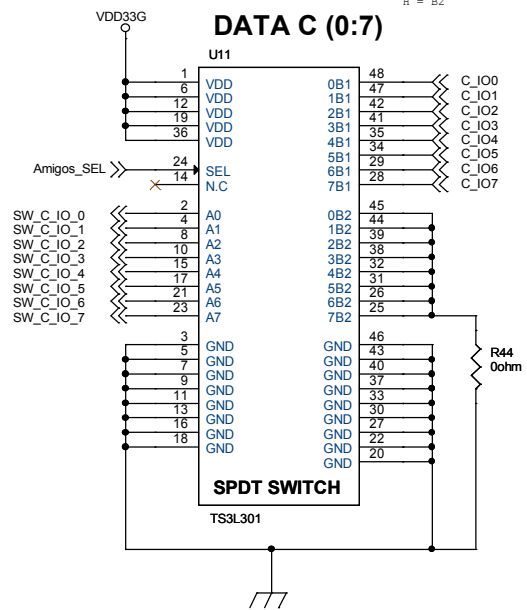

Amigos Mode Selector

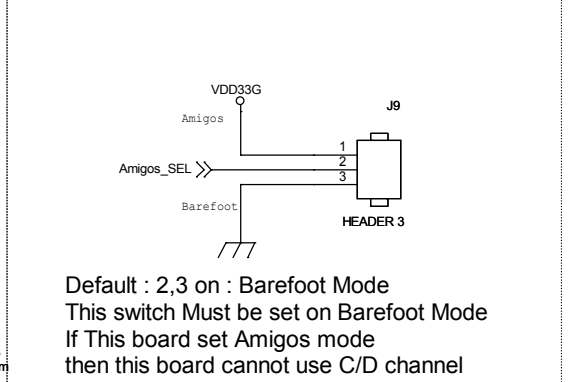

Electric SPDP Switch

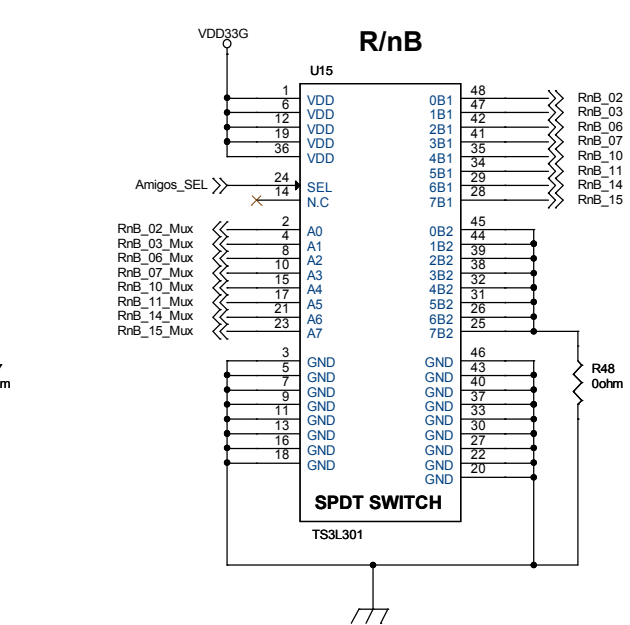
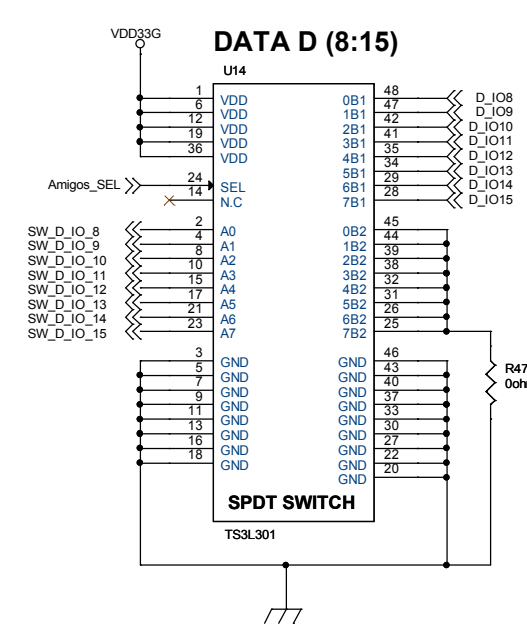

Amigos Mode Set Indicator

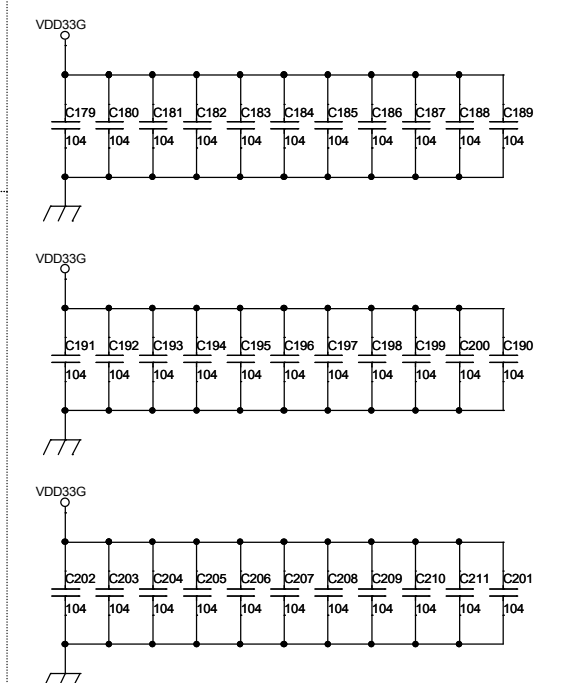
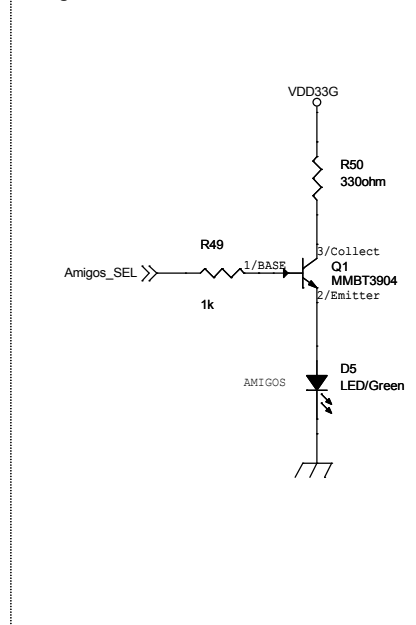

OpenSSD Project		
Title	Jasmine Board / SPDT SWITCH	
Size B	Document Number	Rev 1
	INDTC08-081022-B-SCH	
Date:	Friday, April 29, 2011	Sheet 9 of 13

Controller GPIO Section

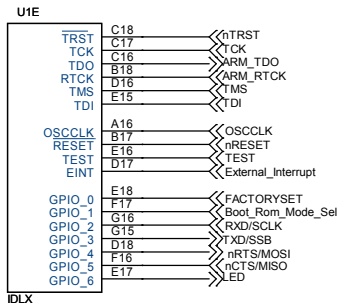

GPIO Mode Set Switch

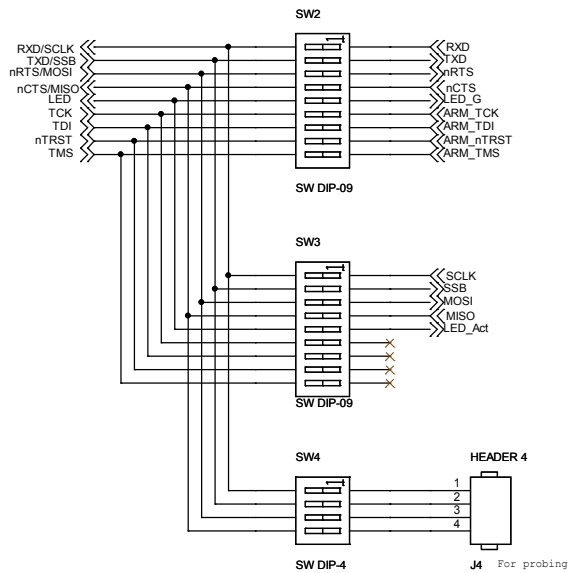

Factory Mode Set Header

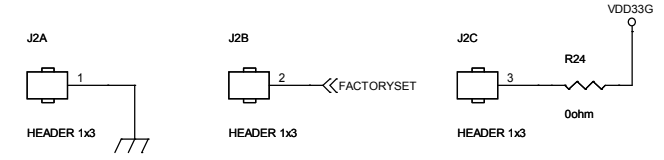

Reset with External S/W (nRESET)

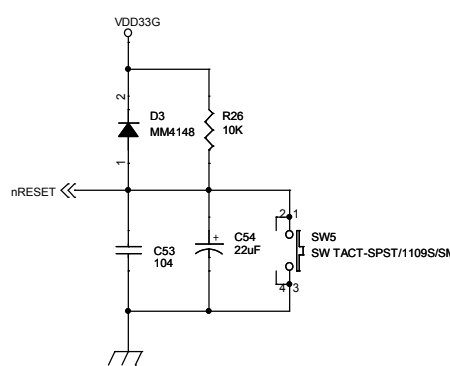

GPIO Jumper

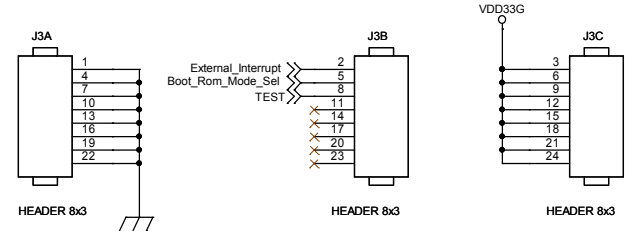

External Eeprom

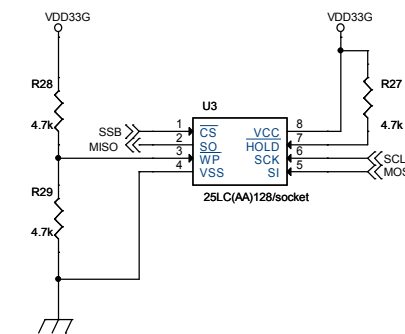

Clock Source / Oscillator / 50Mhz

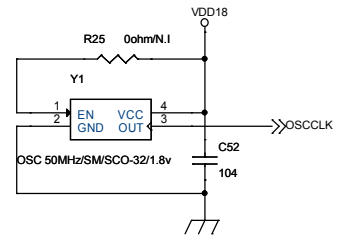

LED Indicator

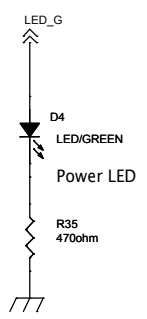

J-TAG Box Header

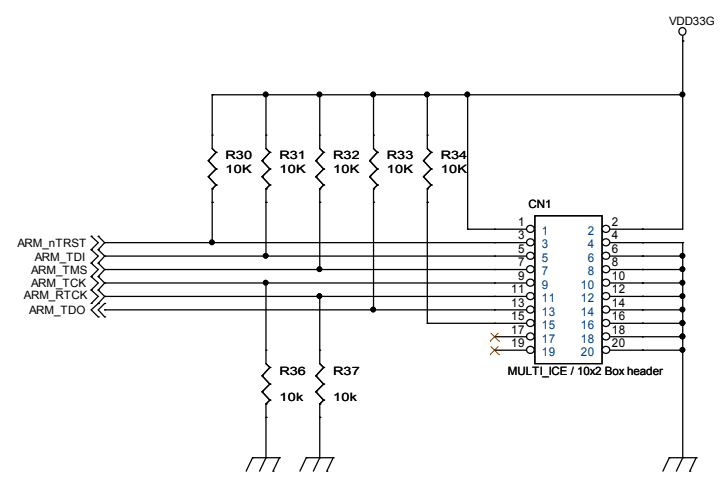

UART Port / RS-232C

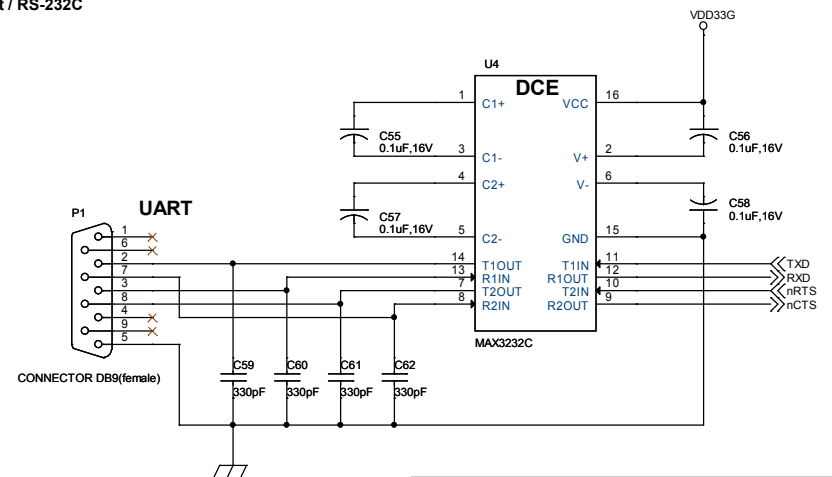

OPENSSD Project			
Title	Jasmine Board / GPIO / Uart / Jtag		
Size	Document Number	Rev 1	
A3	INDTC08-081022-B-SCH		
Date:	Friday, April 29, 2011	Sheet	10 of 13

Power Module

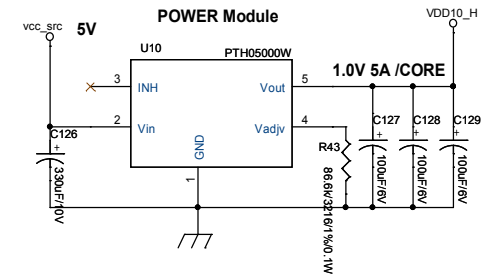
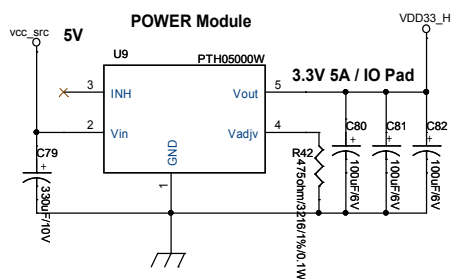
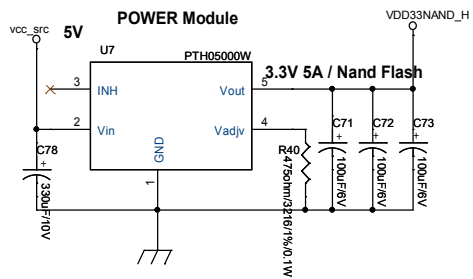
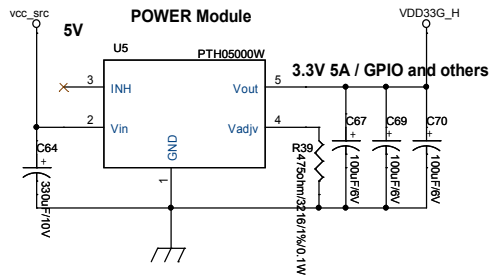

Power Module

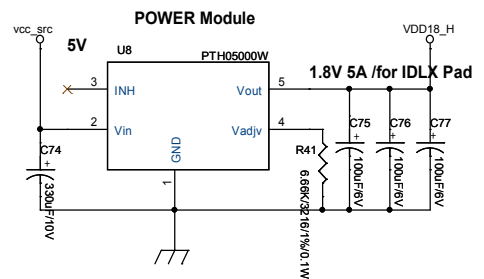
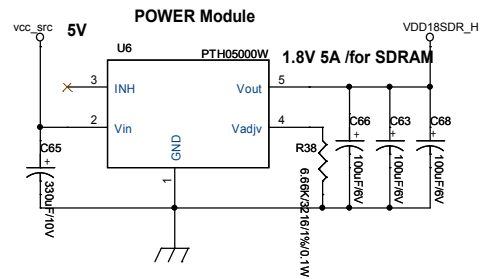

Power Module on/off header pin

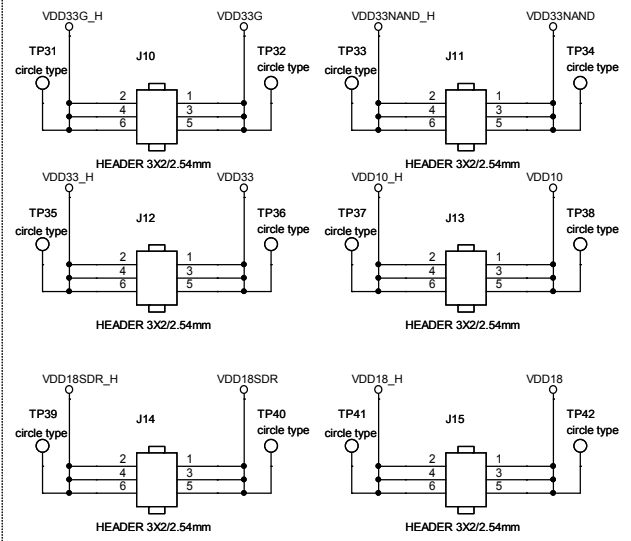

Controller Power section

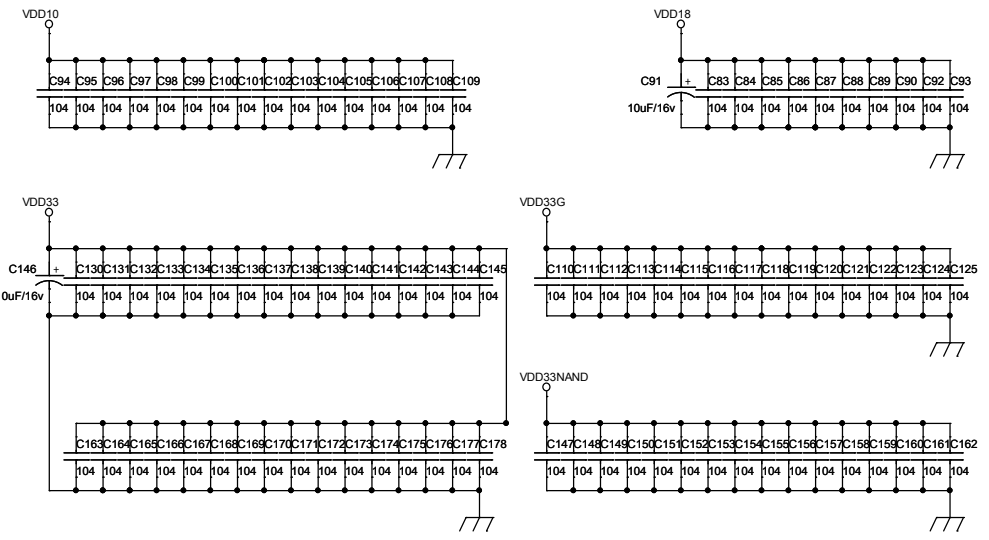
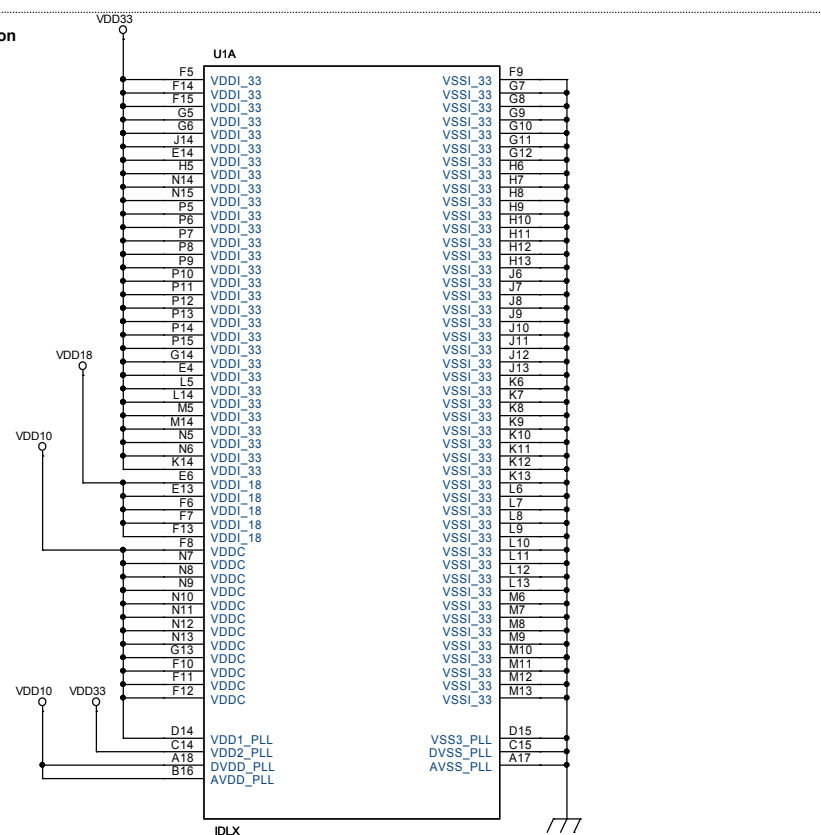

OPENSSD Project			
Title	Jasmine Board / Power		
Size	Document Number	INDTC08-081022-B-SCH	Rev 1
Date:	Friday, April 29, 2011	Sheet	11 of 13

Mictor Connector For Logic Analyzer

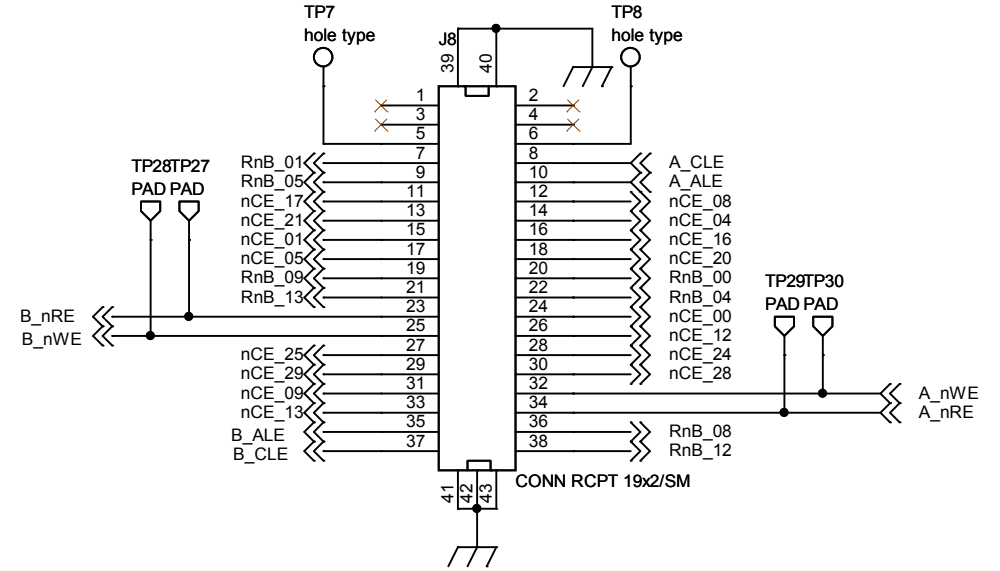
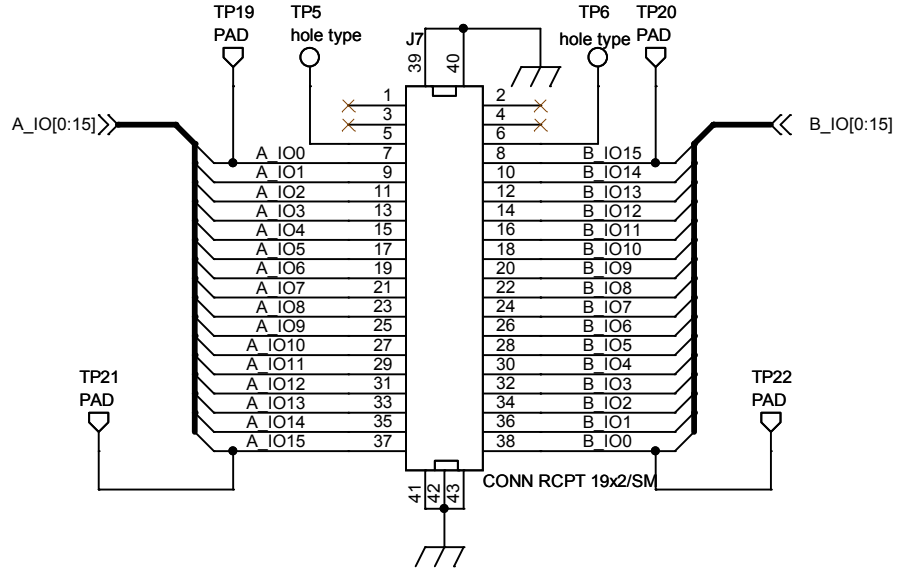
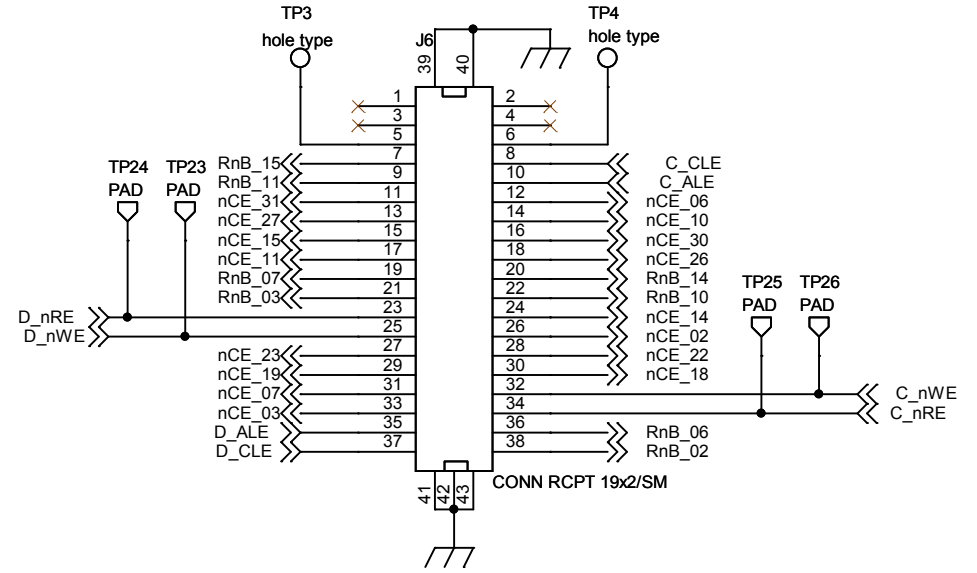
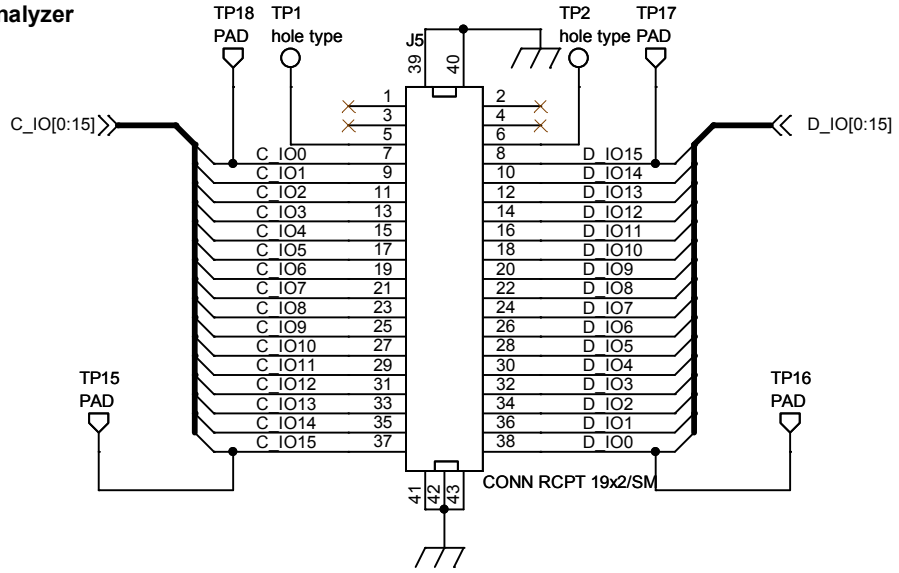

Ground Hook

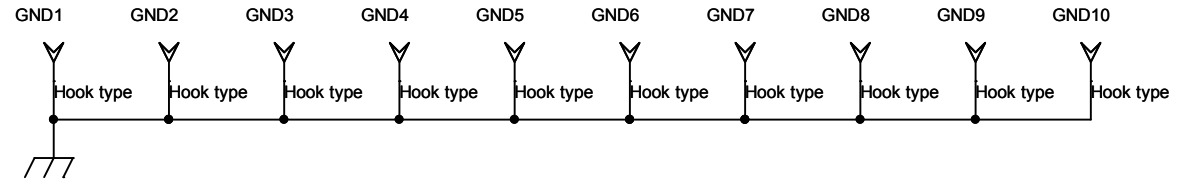

OPENSSED Project		
Title Jasmine Board / Mictor for probing		
Size A4	Document Number INDTC08-081022-B-SCH	Rev 1
Date Friday, April 29, 2011	Sheet 12	of 13

Default Set

Mode	Part	N.O	Status
GPIO JUMPER	J3	-	HIGH
		2,5,8	LOW
		14,17,20,23	DON'T CARE
FACTORY SET	J2	J2.A, J2.B	INSERT JUMPER CAP
J-TAG	SW2	6,7,8,9	ON
	SW3	6,7,8,9	OFF
	SW4	-	DON'T CARE
UART	SW2	1,2,3,4,	ON
	SW3	1,2,3,4,	OFF
	SW4	1,2,3,4,	OFF
ACTIVITY LED	SW2	5	OFF
	SW3	5	ON
	SW4	-	DON'T CARE
EXTERNAL EEPROM	-	-	DON'T USE

OPENSSED Project		
Title Jasmine Board / DEFAULT SET TABLE		
Size A	Document Number INDTC08-081022-B-SCH	Rev 1
Date:	Friday, April 29, 2011	Sheet 13 of 13